

Transmission and Distribution of Electrical Power



By



Assis. Prof. / Mohamed Ahmed Ebrahim Mohamed

E-mail: mohamedahmed_en@yahoo.com

Web site: <http://bu.edu.eg/staff/mohamedmohamed033>





Lecture (3)



Overhead Line Insulators

What is Overhead Line Insulator?

Overhead line insulator is insulating fixture that is used to secure the conductors of an overhead transmission (or distribution) from current leakage to the earth through the supports.



Characteristics of Overhead Line Insulators

- **Mechanically very strong in order to withstand the load due to weight of the conductors.**
- **High relative permittivity in order to give high dielectric strength.**
- **High ratio of rupture to flash-over voltage.**

Characteristics of Overhead Line Insulators

- **High insulation resistance in order to avoid leakage of current to earth.**
- **The material employed should not be porous and there should be no effect of change in temperature.**
- **Free from internal impurities and crack and should be impervious to the fluids and gases in the atmosphere.**

Characteristics of Overhead Line Insulators

High insulation resistance

High Relative Permittivity

Mechanically Very Strong

Free from internal impurities and crack

High Ratio of Rupture to Flash-Over Voltage

Impervious to the fluids and gases in the atmosphere

Insulation Material

Porcelain

* Advantages

- * Mechanically strong
- * Its surface is not affected by dirt deposits
- * Less susceptible to temperature changes

* Disadvantage

- * It is not so homogeneous as glass.
- * It is not transparent



Insulation Material

Glass

* Advantages

- * cheaper than porcelain
- * It has a lower coefficient of thermal expansion

* Disadvantages

- * moisture more readily condense on its surface



Insulation Material

Steatite

* Advantages

- * It can be used at tension towers

* Disadvantages

- * It has a much higher tensile and bending stress

Types of insulators

Pin type insulator



Types of insulators

Suspension type insulator

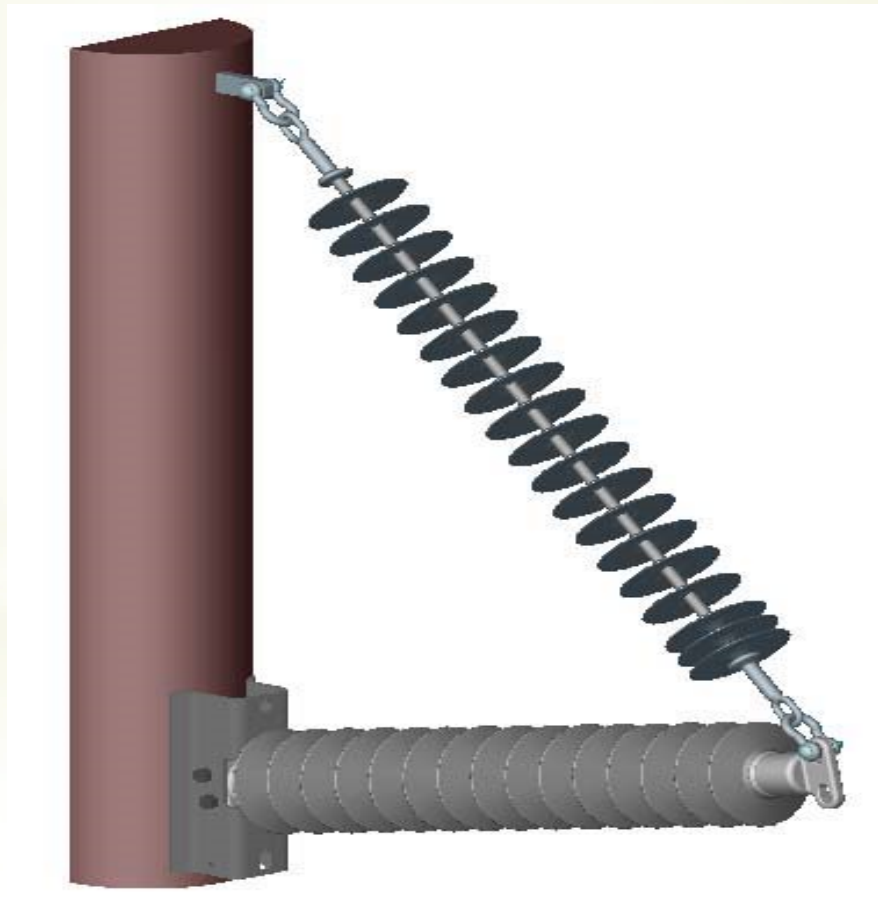

Types of insulators

Strain insulator

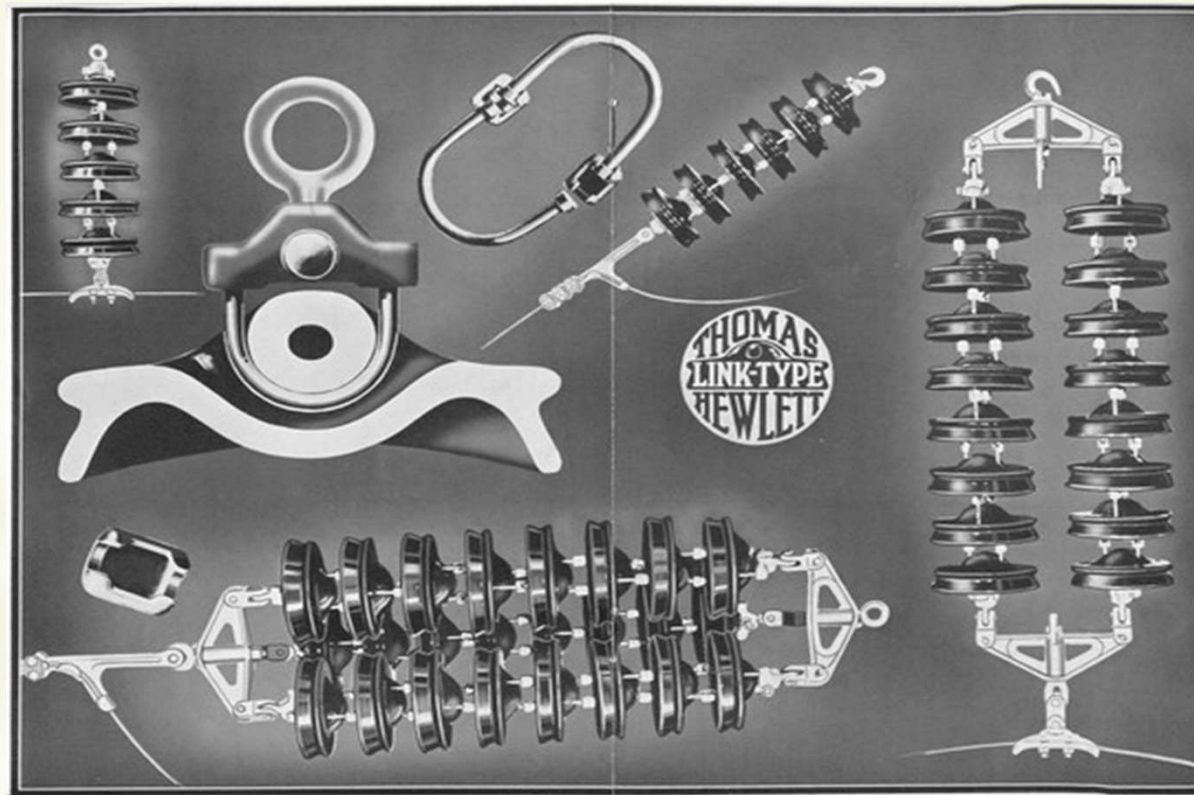

insulators Failure

*The causes of the failure of insulators are given below:

- *Cracking of insulator
- *Porosity of the material
- *Improper verification
- *Flashover
- *Mechanical stresses
- *Short circuit
- *Deposition of dust

Potential distribution over a string of suspension insulators

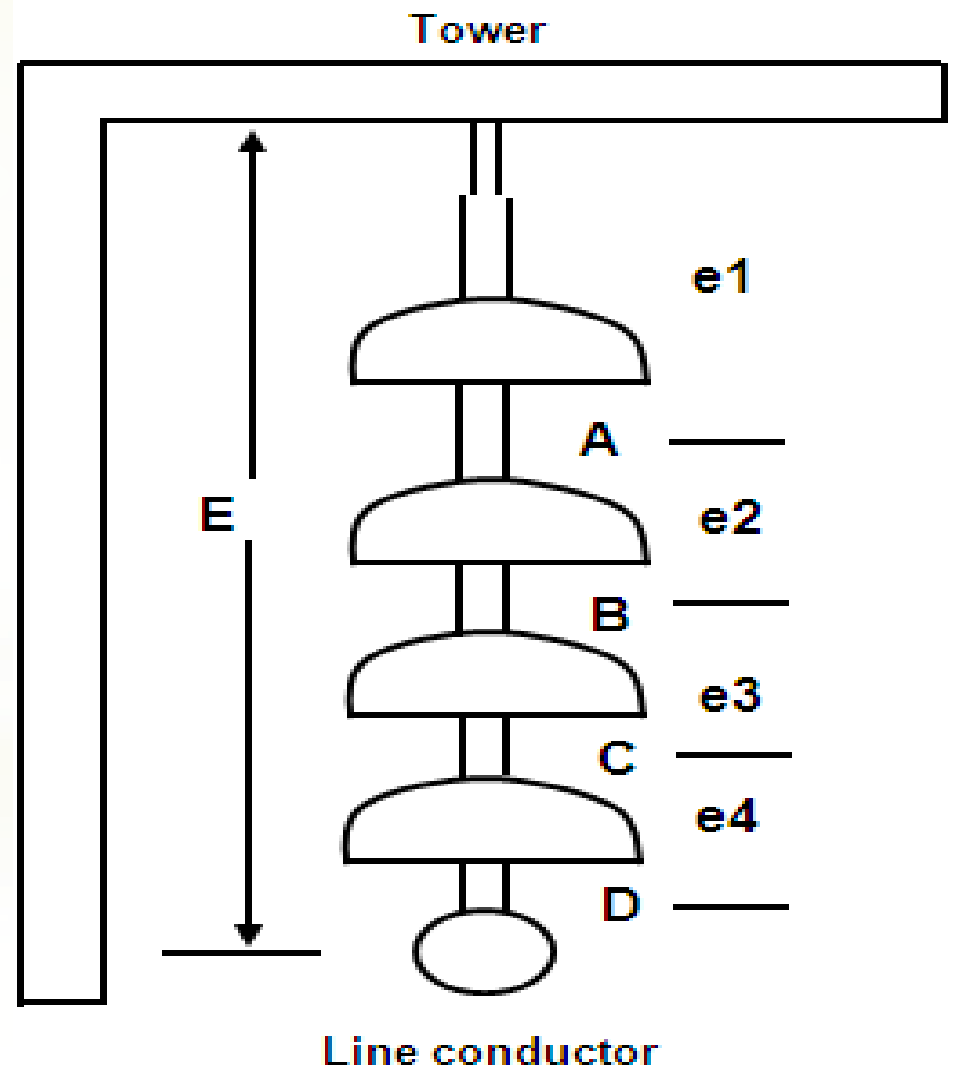
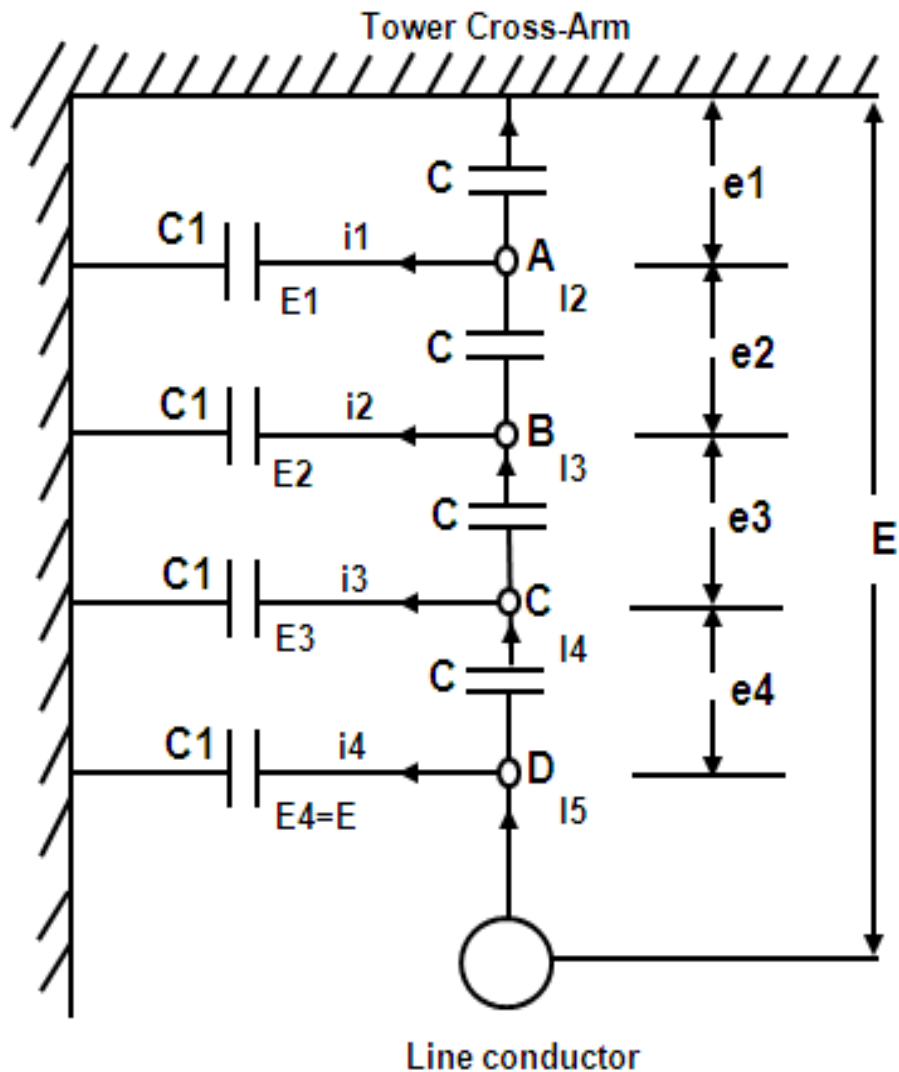

Methods of Improving String Efficiency

- **Long Cross-arm Method** (decreasing the value of K): The string efficiency increases with the decrease in the value of K . K can be decreased by using long cross-arms. But the limitation of cost and strength doesn't allow the cross-arms to be too long. In practice K shouldn't be less than 0.1.

Methods of Improving String Efficiency

- **Capacitance Grading Method:** Uniform voltage distribution across units of string of suspension insulators can be achieved by grading the mutual capacitance of the units by having the lower units of more capacitance - maximum at the line unit and minimum at the top unit, nearest to the cross-arms.

At $K=0.1$

n (unit no.)	e_n (unit voltage)
1	0.1414
2	0.1556
3	0.1856
4	0.2342
5	0.3065
6	0.4097
7	0.5542
8	0.7546
9	1.031
10	1.4115

At $K=0.1$

11	1.9342
12	2.652
13	3.6373
14	4.9893
15	6.8444
16	9.3896
17	12.8817
18	17.6727
19	24.2457
20	33.2636
21	45.6357
22	62.6095

At $K=0.1$

$$\% \text{ Efficiency} = \eta = 16.7663$$

At $K=0.25$

n (unit no.)	e_n (unit voltage)
1	0.004
2	0.005
3	0.0074
4	0.0116
5	0.0187
6	0.0306
7	0.0503
8	0.0829
9	0.1366
10	0.2253

At $K=0.25$

11	0.3714
12	0.6123
13	1.0095
14	1.6643
15	2.744
16	4.524
17	7.4589
18	12.2976
19	20.2753
20	33.4284
21	55.1141
22	90.8678

At $K=0.25$

$$\% \text{ Efficiency} = \eta = 11.5522$$

Conclusion

***From the previous tables we note that the string efficiency decreases with the increase in the value of K.**

***By using guard ring the efficiency becomes about 95-99%.**

**Thank You
For Your Attention**



*Mohamed Ahmed
Ebrahim*